

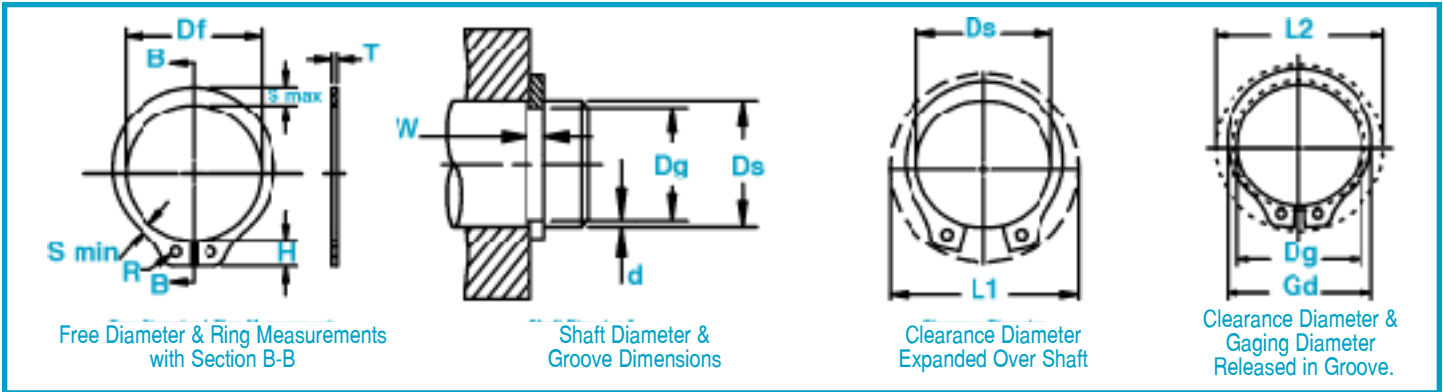

# SH Shaft Rings

## Axially Assembled, External

Once installed in the groove of a shaft, the shoulder holds an assembly in place.



RING NO.	SHAFT DIAMETER D			GROOVE SIZE					RING SIZE & WEIGHT				CLEARANCE DIA.			THRUST LD. (lbs.)	
				DIAMETER		WIDTH		DEPTH	FREE DIAMETER		THICKNESS***		eight Per 1000 pcs.	Expanded over Shaft	Re-leased in Groove	Sqr. Corner Abutment	
	Ds DEC	Ds FRAC	Ds mm	Dg	Tol.	W	Tol.	d	Df	Tol.	T	Tol.				lbs.	L1
**SH-12	.125	1/8	3.2	.117		.012		.004	.112		.010	±.001	.018	.222	.214	112	35
**SH-15	.156	5/32	4.0	.146		.012		.005	.142		.010		.037	.27	.260	132	55
**SH-18	.188	3/16	4.8	.175	±.0015	.018	+.002	.006	.168	+.002	.015		.059	.298	.286	244	80
**SH-19	.197	-	5.0	.185	.0015*	.018	-.000	.006	.179	-.004	.015		.063	.319	.307	254	85
**SH-21	.219	7/32	5.6	.205		.018		.007	.196		.015		.074	.338	.324	284	110
**SH-23	.236	15/64	6.0	.222		.018		.007	.215		.015		.086	.355	.341	315	120
SH-25	.250	1/4	6.4	.230		.029		.010	.225		.025		.21	.45	.43	599	175
SH-27	.276	-	7.0	.255		.029		.010	.250		.025		.23	.48	.46	660	195
SH-28	.281	9/32	7.1	.261		.029		.010	.256		.025		.24	.49	.47	670	200
SH-31	.312	5/16	7.9	.290		.029		.011	.281		.025		.27	.54	.52	751	240
SH-34	.344	11/32	8.7	.321	±.002	.029		.011	.309		.025		.31	.57	.55	812	265
SH-35	.354	-	9.0	.330	.002*	.029		.012	.320	+.002	.025		.35	.59	.57	832	300
SH-37	.375	3/8	9.5	.352		.029		.012	.338	-.005	.025		.39	.61	.59	883	320
SH-39	.394	-	10.0	.369		.029		.012	.354		.025		.42	.62	.60	954	335
SH-40	.406	13/32	10.3	.382		.029		.012	.366		.025		.43	.63	.61	964	350
SH-43	.438	7/16	11.1	.412		.029		.013	.395		.025		.50	.66	.64	1035	400
SH-46SP	.461	-	11.7	.435		.029		.013	.420		.025		.51	.68	.66	1110	460
SH-46	.469	15/32	11.9	.443		.029		.013	.428		.025	±.002	.54	.68	.66	1117	450
SH-50	.500	1/2	12.7	.468	±.002	.039	+.003	.016	.461		.035		.91	.77	.74	1675	550
SH-55	.551	-	14.0	.519	.004*	.039	-.000	.016	.509		.035		.90	.81	.78	1800	600
SH-56	.562	9/16	14.3	.530		.039		.016	.521		.035		1.1	.82	.79	1878	650
SH-59	.594	19/32	15.1	.559		.039		.017	.550		.035		1.2	.86	.83	1979	750
SH-62	.625	5/8	15.9	.588		.039		.018	.579		.035		1.3	.90	.87	2091	800
SH-66	.669	-	17.0	.629		.039		.020	.621	+.005	.035		1.4	.93	.89	2233	950
SH-66	.672	43/64	17.1	.631		.039		.020	.621	-.010	.035		1.4	.93	.89	2233	950
SH-68	.688	11/16	17.5	.646		.046		.021	.635		.042		1.8	1.01	.97	3451	1000
SH-75	.750	3/4	19.0	.704	±.003	.046		.023	.693		.042		2.1	1.09	1.05	3756	1200
SH-78	.781	25/32	19.8	.733	.004*	.046		.024	.722		.042		2.2	1.12	1.08	3959	1300
SH-81	.812	13/16	20.6	.762		.046		.025	.751		.042		2.5	1.15	1.10	4060	1450
SH-84	.844	-	21.4	.791		.046		.026	.780		.042		2.7	1.18	1.13	4200	1500
SH-87	.875	7/8	22.2	.821		.046		.027	.810		.042		2.8	1.21	1.16	4365	1650
SH-93	.938	15/16	23.8	.882		.046		.028	.867		.042		3.1	1.34	1.29	4720	1850
SH-98	.984	63/64	25.0	.926		.046		.029	.910		.042		3.5	1.39	1.34	4923	2000
SH-100	1.000	1	25.4	.940		.046		.030	.925		.042		3.6	1.41	1.35	5024	2100
SH-102	1.023	-	26.0	.961		.046		.031	.946		.042		3.9	1.43	1.37	5126	2250
SH-106	1.062	1-1/16	27.0	.998	±.004	.056	+.004	.032	.982	+.010	.050		4.8	1.50	1.44	6293	2400
SH-112	1.125	1-1/8	28.6	1.059	.005*	.056	-.000	.033	1.041	-.015	.050		5.1	1.55	1.49	6699	2600

\*\*SIZES -12 THRU -23 STANDARD MATERIAL- CARBON STEEL; OPTIONAL MATERIAL- BERYLLIUM COPPER.

\* F.I.M. (FULL INDICATOR MOVEMENT)- MAXIMUM ALLOWABLE DEVIATION OF CONCENTRICITY BETWEEN GROOVE & SHAFT.

† BASED ON HOUSINGS/SHAFTS MADE OF COLD ROLLED STEEL. FOR AN EXPLANATION OF FORMULAS USED TO DERIVE THRUST LOAD AND OTHER PERFORMANCE DATA CONTACT THE ROTOR CLIP ENGINEERING DEPARTMENT.

\*\*\*FOR PLATED RINGS ADD .002" TO THE LISTED MAXIMUM THICKNESS. MAXIMUM THICKNESS WILL BE A MINIMUM OF .0002" LESS THAN THE LISTED GROOVE WIDTH (W) MINIMUM.

# For technical assistance call 1-800-55-ROTOR

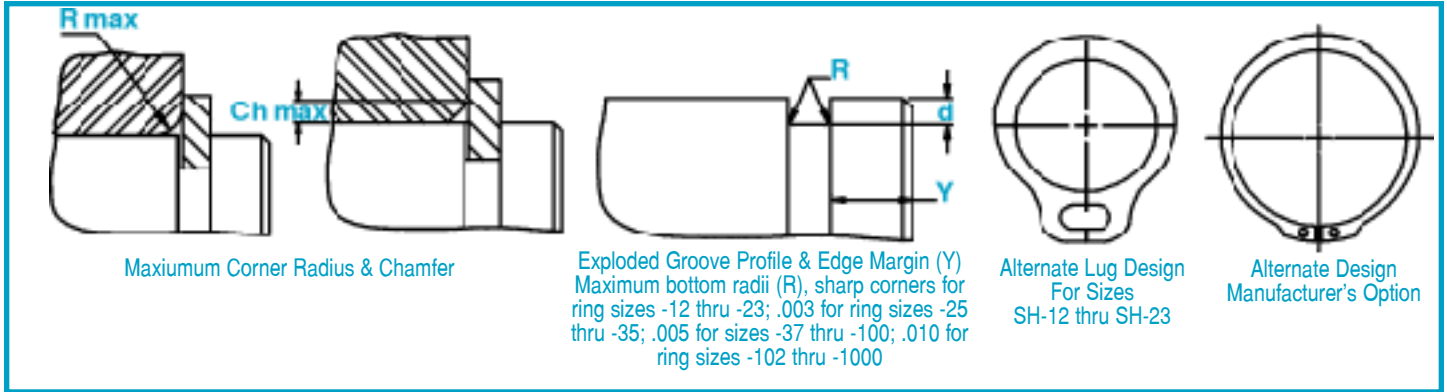

RING NO.	LUG HEIGHT		MAXIMUM D SECTION		MINIMUM SECTION		HOLE DIAMETER		GAGING DIA.	ALLOWABLE CORNER RADII & CHAMFERS			MAX. LOAD w/ R max or Ch max (lbs.)	EDGE MARGIN	R.P.M. LIMITS Standard Material
	H	Tol.	S max	Tol.	S min	Tol.	R	Tol.		Gd Max	R max	Ch max			
**SH-12	.046	±.002	.018	±.0015	.011	±.0015	.026		.148	.010	.006	45	.012	80000	
**SH-15	.054		.026		.016		.026		.189	.015	.009	45	.015	80000	
**SH-18	.050		.025		.016		.025		.218	.014	.0085	105	.018	80000	
**SH-19	.056		.026		.016		.026		.229	.0145	.009	105	.018	80000	
**SH-21	.056		.028		.017		.026		.252	.015	.009	105	.021	80000	
**SH-23	.056	.030	.019	.026	.272	.0165	.010	105	.021	80000					
SH-25	.080	±.003	.035	±.003	.025	±.003	.041	+.010 -.002	.290	.018	.011	470	.030	80000	
SH-27	.081		.035		.024		.041		.315	.0175	.0105	470	.031	76000	
SH-28	.080		.038		.025		.041		.326	.020	.012	470	.030	74000	
SH-31	.087		.040		.026		.041		.357	.020	.012	470	.033	70000	
SH-34	.087		.042		.0265		.041		.390	.021	.0125	470	.033	64000	
SH-35	.087		.046		.029		.041		.405	.023	.014	470	.036	62000	
SH-37	.088		.050		.0305		.041		.433	.026	.0155	470	.036	60000	
SH-39	.087		.052		.031		.041		.452	.027	.016	470	.037	56500	
SH-40	.087		.054		.033		.041		.468	.0285	.017	470	.036	55000	
SH-43	.088		.055		.033		.041		.501	.029	.0175	470	.039	50000	
SH-46SP1	.092		.064		.038		.041		.540	.015	.017	470	.039	42000	
SH-46	.088		.060		.035		.041		.540	.031	.018	470	.039	42000	
SH-50	.108		.065		.040		.047		.574	.034	.020	910	.048	40000	
SH-55	.108		.053		.036		.047		.611	.027	.0165	910	.048	36000	
SH-56	.108		.072		.041		.047		.644	.038	.023	910	.048	35000	
SH-59	.109	.076	.043	.047	.680	.0395	.0235	910	.052	32000					
SH-62	.110	.080	.045	.047	.715	.0415	.025	910	.055	30000					
SH-66	.110	.082	.043	.047	.756	.040	.024	910	.060	29000					
SH-66	.110	.082	.043	.047	.758	.040	.024	910	.060	29000					
SH-68	.136	.084	.048	.052	.779	.042	.025	1340	.063	28000					
SH-75	.136	.092	.051	.052	.850	.046	.0275	1340	.069	26500					
SH-78	.136	.094	.052	.052	.883	.047	.028	1340	.072	25500					
SH-81	.136	.096	.054	.052	.914	.047	.028	1340	.075	24500					
SH-84	.137	.100	.057	.052	.950	.047	.028	1340	.078	24000					
SH-87	.137	.104	.057	.052	.987	.051	.0305	1340	.081	23000					
SH-93	.166	.110	.063	.078	1.054	.055	.033	1340	.084	21500					
SH-98	.167	.114	.064	.078	1.106	.056	.0335	1340	.087	20500					
SH-100	.167	.116	.065	.078	1.122	.057	.034	1340	.090	20000					
SH-102	.168	.118	.066	.078	1.147	.058	.035	1340	.093	19500					
SH-106	.181	.122	.069	.078	1.192	.060	.036	1950	.096	19000					
SH-112	.182	.128	.071	.078	1.261	.063	.038	1950	.099	18800					

FOR HARDNESS SPECIFICATIONS, SEE END OF THIS SECTION.