

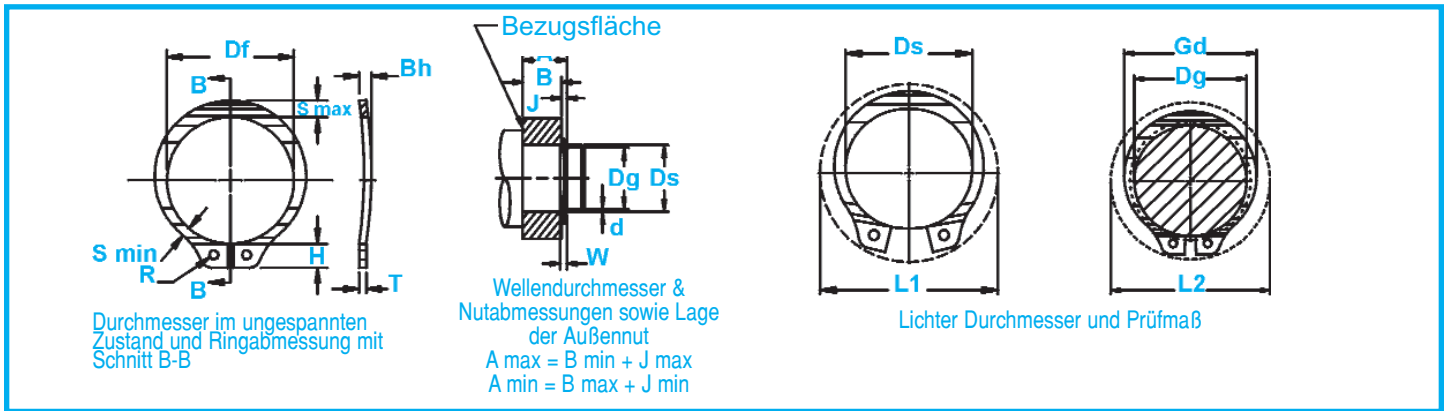

BSH Sicherungsringe für Wellen



RING NR.	WELLE			NUTGRÖÖE				RINGGRÖÖE & GEWICHT						LICHTER DURCHM.		AXIALBELASTUNG(lbs.) bei rechtwinkliger Anlage			
	DURCHMESSER			DURCHMESSER	BREITE	TIEFE	DURCHMESSER IM UNGESpanNTEN ZUSTAND	DICKE***	HÖHE DER WÖLBUNG	Gewicht pro 1000 Stück	Auf der Welle aufgeweitet	In der Nut entspannt	Ring Sicherheitsfaktor	Nut Sicherheitsfaktor					
	Dh DEZ.	Dh BRUCH	Dh mm	Dg	Tol.	W	Tol.	d	Df						Tol.	T	Tol.	Bh	Tol.
BSH-25	.250	1/4	6.4	.230	±.0015.0015*	.040		.010	.225	+ .002-.004	.025		.047		.21	.45	.43	599	175
BSH-27	.276	-	7.0	.255		.040		.010	.250		.025		.047		.23	.48	.46	660	195
BSH-28	.281	9/32	7.1	.261		.040		.010	.256		.025		.047		.24	.49	.47	670	200
BSH-31	.312	5/16	7.9	.290		.040		.011	.281		.025		.047		.27	.54	.52	751	240
BSH-34	.344	11/32	8.7	.321		.040		.011	.309		.025		.047		.31	.57	.55	812	265
BSH-35	.354	-	9.0	.330	±.002	.040		.012	.320	+ .002	.025	±.002	.047	±.006	.35	.59	.57	832	300
BSH-37	.375	3/8	9.5	.352	.002*	.040		.012	.338	- .005	.025		.047		.39	.61	.59	883	325
BSH-39	.394	-	10.0	.369		.040		.012	.354		.025		.047		.42	.62	.60	954	335
BSH-40	.406	13/32	10.3	.382		.040		.012	.366		.025		.047		.43	.63	.61	964	350
BSH-43	.438	7/16	11.1	.412		.040		.013	.395		.025		.047		.50	.66	.64	1035	400
BSH-46	.469	15/32	11.9	.443		.040		.013	.428		.025		.047		.54	.68	.66	1117	450
BSH-50	.500	1/2	12.7	.468		.055		.016	.461		.035		.063		.91	.77	.74	1675	550
BSH-55	.551	-	14.0	.519	±.002	.055	+ .003	.016	.509		.035		.063	±.007	.90	.81	.78	1827	600
BSH-56	.562	9/16	14.3	.530	.004*	.055	- .000	.016	.521		.035		.063		1.1	.82	.79	1878	650
BSH-59	.594	19/32	15.1	.559		.055		.017	.550		.035		.063		1.2	.86	.83	1979	750
BSH-62	.625	5/8	15.9	.588		.055		.018	.579		.035		.063		1.3	.90	.87	2091	800
BSH-66	.669	-	17.0	.629		.055		.020	.621		.035		.063		1.4	.93	.89	2233	950
BSH-66	.672	43/64	17.1	.631		.055		.020	.621		.035		.063		1.4	.93	.89	2233	950
BSH-68	.688	11/16	17.5	.646	±.003	.062		.021	.635	+ .005	.042		.073	±.008	1.8	1.01	.97	3451	1000
BSH-75	.750	3/4	19.0	.704	.004*	.062		.023	.693	- .010	.042		.073		2.1	1.09	1.05	3756	1200
BSH-78	.781	25/32	19.8	.733		.062		.024	.722		.042		.073		2.2	1.12	1.08	3959	1300
BSH-81	.812	13/16	20.6	.762		.062		.025	.751		.042		.073		2.5	1.15	1.10	4060	1450
BSH-87	.875	7/8	22.2	.821		.062		.027	.810		.042		.073		2.8	1.21	1.16	4365	1650
BSH-93	.938	15/16	23.8	.882		.062		.028	.867		.042		.073		3.1	1.34	1.29	4720	1850
BSH-98	.984	63/64	25.0	.926		.062		.029	.910		.042		.073		3.5	1.39	1.34	4923	2000
BSH-100	1.000	1	25.4	.940		.062		.030	.925		.042		.073		3.6	1.41	1.35	5024	2100
BSH-102	1.023	-	26.0	.961		.062		.031	.946		.042		.073		3.9	1.43	1.37	5126	2250
BSH-106	1.062	1-1/16	27.0	.998		.070		.032	.982		.050		.085		4.8	1.50	1.44	6293	2400
BSH-112	1.125	1-1/8	28.6	1.059		.070		.033	1.041		.050		.085		5.1	1.55	1.49	6699	2600
BSH-118	1.188	1-3/16	30.2	1.118		.070		.035	1.098		.050		.085		5.6	1.61	1.54	7105	2950
BSH-125	1.250	1-1/4	31.7	1.176		.070		.037	1.156		.050		.085		5.9	1.69	1.62	7460	3250
BSH-131	1.312	1-5/16	33.3	1.232	±.004	.070		.040	1.214	+ .010	.050		.085	±.012	6.8	1.75	1.67	7866	3700
BSH-137	1.375	1-3/8	34.9	1.291	.005*	.070		.042	1.272	- .015	.050		.085		7.2	1.80	1.72	8222	4100
BSH-143	1.438	1-7/16	36.5	1.350		.070		.044	1.333		.050		.085		8.1	1.87	1.79	8628	4500
BSH-150	1.500	1-1/2	38.1	1.406		.070		.047	1.387		.050		.085		9.0	1.99	1.90	8932	5000
BSH-162	1.625	1-5/8	41.3	1.529	±.005	.096	+ .005	.048	1.503	+ .013	.062	±.003	.115	±.015	13.2	2.17	2.08	12028	5500
BSH-175	1.750	1-3/4	44.4	1.650	.005*	.096	- .000	.050	1.618	- .020	.062		.115		15.3	2.31	2.21	12992	6200

*GESAMTER ANZEIGENAUSSCHLAG -MAXIMAL ZULÄSSIGE RUNDLAUFABWEICHUNG ZWISCHEN NUT UND GEHÄUSE

† BASIEREND AUF GEHÄUSEN/WELLEN AUS KALTGEWALZTEM STAHL. FRAGEN ZU DEN FORMELN, DIE ZUR ABLEITUNG DER AXIALBELASTUNG UND DER ANDEREN LEISTUNGSKENNDATEN VERWENDET WURDEN, BITTE AN DIE ABTEILUNG ROTOR CLIP ENGINEERING RICHTEN.

*** DIE AUFGEFÜHRTE MAXIMALE DICKE BEI GALVANISCH BEHANDELTEN RINGEN ZUZÜGLICH 0,002 INCH. DIE MAXIMALE RINGDICKE

IST UM MINDESTENS 0,0002 INCH KLEINER ALS DIE AUFGEFÜHRTE MINIMALE NUTBREITE (W). HÄRTEBEREICH: EDELSTAHLRINGE (PH 15-7MO)

RINGSORTE	GRÖÖENBEREICH	SKALA	ROCKWELL HÄRTE
BSH	25-81	30N	63-69.5
	87+	C	44-51

Axialmontiert, für Wellen, Gewölbt

Nachdem der Ring in der Nut eingesetzt ist, übt er Druck auf das zu sichernde Teil für den ringspezifischen Bereich aus.

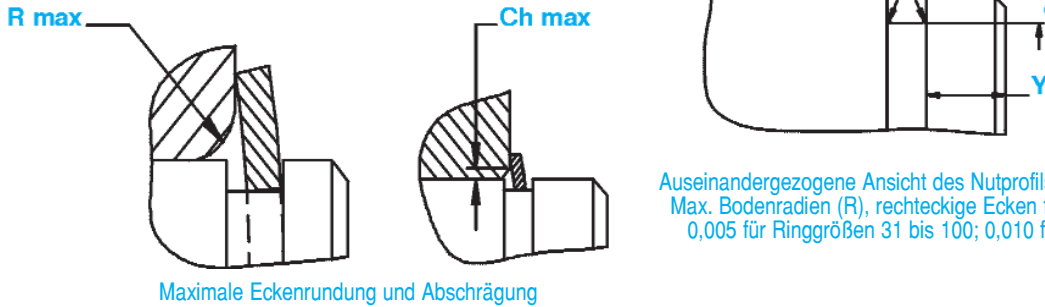

Auseinandergezogene Ansicht des Nutprofils und Kantenabstands (Y)
Max. Bodenradien (R), rechteckige Ecken für Ringgrößen 25 bis 35;
0,005 für Ringgrößen 31 bis 100; 0,010 für Ringgrößen ab 102.

Maximale Eckenrundung und Abschrägung

RING NR.	Abstand zwischen Nutaußenwand und Stirnfläche des festgehaltenen Bauteils		AUSGLEICH gefederter Ausgleich von Toleranzen a & b J max- J min	Erforderliche KRAFT um Ringe flach zu drücken lbs.	Zulässige Eckenrundungen und Abschrägungen		MAX Belastung bei R max od. Ch max (in lbs.) P'r	Kantenabstand Y	AUGEN HÖHE H	Tol.	MAXIMALER Querschnitt		MINIMALER Querschnitt		Montageloch Durchmesser		PRÜFMAB Gd Max	U/MIN Grenzwerte Standard material	
	J min	J max			R max	Ch max					S max	Tol.	S min	Tol.	R	Tol.			
BSH-25	.030	.038	.008	50	.018	.011	470	.030	.080		.035		.025		.041		.290	80000	
BSH-27	.030	.038		50	.0175	.0105	470	.031	.081		.035		.024		.041		.315	76000	
BSH-28	.030	.038		50	.020	.012	470	.030	.080		.038		.0255		.041		.326	74000	
BSH-31	.030	.038		50	.020	.012	470	.033	.087		.040		.026		.041		.357	70000	
BSH-34	.030	.038		45	.021	.0125	470	.033	.087		.042		.0265		.041		.390	64000	
BSH-35	.030	.038		45	.023	.014	470	.036	.087	±.003	.046	±.003	.029	±.003	.041	+.010	.405	62000	
BSH-37	.030	.038		45	.026	.0155	470	.036	.088		.050		.0305		.041	-.002	.433	60000	
BSH-39	.030	.038		40	.027	.016	470	.037	.087		.052		.031		.041		.452	56500	
BSH-40	.030	.038		40	.0285	.017	470	.036	.087		.054		.033		.041		.468	55000	
BSH-43	.030	.038		35	.029	.0175	470	.039	.088		.055		.033		.041		.501	50000	
BSH-46	.030	.038		35	.031	.018	470	.039	.088		.060		.035		.041		.540	42000	
BSH-50	.042	.053		.011	90	.034	.020	910	.048	.108		.065		.040		.047		.574	40000
BSH-55	.042	.053			85	.027	.0165	910	.048	.108		.053		.036		.047		.611	36000
BSH-56	.042	.053			80	.038	.023	910	.048	.108		.072	±.004	.041	±.004	.047		.644	35000
BSH-59	.042	.053			70	.0395	.0235	910	.052	.109		.076		.043		.047		.680	32000
BSH-62	.042	.053	60		.0415	.025	910	.055	.110		.080		.045		.047		.715	30000	
BSH-66	.042	.053	50		.040	.024	910	.060	.110		.082		.043		.047		.756	29000	
BSH-66	.042	.053	50		.040	.024	910	.060	.110		.082		.043		.047		.758	29000	
BSH-68	.049	.060	70		.042	.025	1340	.063	.136		.084		.048		.052		.779	28000	
BSH-75	.049	.060	65		.046	.0275	1340	.069	.136		.092		.051		.052		.850	26500	
BSH-78	.049	.060	60		.047	.028	1340	.072	.136		.094		.052		.052		.883	25500	
BSH-81	.049	.060	55		.047	.028	1340	.075	.136		.096		.054		.052		.914	24500	
BSH-87	.049	.060	45		.051	.035	1340	.081	.137		.104	±.005	.057	±.005	.052		.987	23000	
BSH-93	.049	.060	40		.055	.033	1340	.084	.166		.110		.063		.078		1.054	21500	
BSH-98	.049	.060	40		.056	.0335	1340	.087	.167		.114		.0645		.078		1.106	20500	
BSH-100	.049	.060	35		.057	.034	1340	.090	.167	±.004	.116		.065		.078		1.122	20000	
BSH-102	.049	.060	35	.058	.035	1340	.093	.168		.118		.066		.078		1.147	19500		
BSH-106	.057	.068	60	.060	.036	1950	.096	.181		.122		.069		.078		1.192	19000		
BSH-112	.057	.068	55	.063	.038	1950	.099	.182		.128		.071		.078		1.261	18800		
BSH-118	.057	.068	50	.064	.0385	1950	.105	.182		.132		.072		.078	+.015	1.325	18000		
BSH-125	.057	.068	45	.068	.041	1950	.111	.183		.140		.076		.078	-.002	1.396	17000		
BSH-131	.057	.068	40	.068	.041	1950	.120	.183		.146	±.006	.0765	±.006	.078		1.458	16500		
BSH-137	.057	.068	35	.072	.043	1950	.126	.184		.152		.082		.078		1.529	16000		
BSH-143	.057	.068	30	.076	.045	1950	.132	.184		.160		.086		.078		1.600	15000		
BSH-150	.057	.068	30	.079	.047	1950	.141	.214		.168		.091		.120		1.668	14800		
BSH-162	.069	.094	.025	55	.087	.052	3000	.144	.235		.180		.097		.125		1.812	13200	
BSH-175	.069	.094		50	.091	.054	3000	.150	.237		.188		.101		.125		1.945	12200	

GRÖßERE GRÖßEN SIND AUF ANFRAGE HIN ERHÄLTICH

HÄRTEBEREICH: BERYLLIUM-KUPFERRINGE

RINGSORTE	GRÖßENBEREICH	SKALA	ROCKWELL HÄRTE
BSH	18-23	15N	77-82*
	25-102	30N	54-62
	106+	C	34-43

*EINE PRÄZISE HÄRTEMESSUNG KANN NICHT DIREKT AN DIESEN RINGEN VORGENOMMEN WERDEN.

HÄRTEBEREICH: KOHLENSTOFFSTAHL-RINGE (SAE 1060-1090)

RINGSORTE	GRÖßENBEREICH	SKALA	ROCKWELL HÄRTE
BSH	25-46	30N	69,5-73
	50-81	30N	66-71
	87-102	C	47-53
	106+	C	47-52

Für die aktuellsten Angaben, Online-Preisangebote & Musterbestellungen, besuchen Sie rotorclip.com