

MC Shaft Rings

Radially Assembled, External Crescent, ANSI Metric

Ideal for low clearance applications where radial installation is preferred.

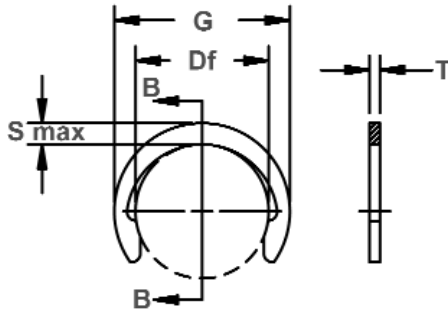

Free Diameter & Ring Measurements With Section B-B

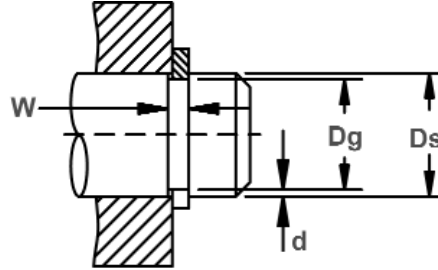

Shaft Diameter & Groove Dimensions

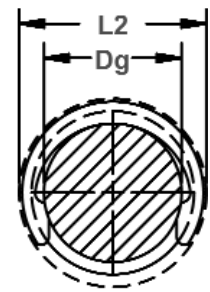

Clearance Diameter Installed In Groove

RING NO.	SHAFT DIAMETER		GROOVE SIZE					RING SIZE & WEIGHT					CLEARANCE DIA.			i THRUST LD (kN)	
			DIAMETER		WIDTH		DEPTH	FREE DIAMETER		THICKNESS***		Wt. Per 1000 Pcs.	Free Outside Dia. Ref.	Re-leased In Groove	Sqr. Corner Abutment	Ring (Safety factor of 3)	Groove (Safety factor of 2)
	Ds mm	Ds DEC	Dg	Tol.	F.I.M.*	W	Tol.	d	Df	Tol.	T						
MC-3	3	0.118	2.3	-0.05	0.04	0.5	+0.10	0.35	2.18	±0.06	0.4		0.019	3.98	4.3	0.4	0.2
MC-4	4	0.157	3.2	-0.07	0.04	0.5		0.40	3.00		0.4		0.025	5.00	5.4	0.5	0.4
MC-5	5	0.197	4.0		0.06	0.7		0.50	3.80		0.6		0.055	6.20	6.6	0.9	0.6
MC-6	6	0.236	5.0	-0.10	0.06	0.7		0.50	4.80	±0.08	0.6		0.072	7.40	7.8	1.1	0.7
MC-7	7	0.276	6.0		0.06	0.7		0.50	5.80	0.6	0.090		8.60	9.0	1.3	0.8	
MC-8	8	0.315	7.0	-0.10	0.06	0.7		0.50	6.80	±0.09	0.6		0.12	10.00	10.4	1.5	1.0
MC-9	9	0.354	8.0		0.06	0.7		0.50	7.80		0.6		0.13	11.20	11.6	2.2	1.1
MC-10	10	0.393	9.0	-0.10	0.06	0.7		0.50	8.75	±0.18	0.6		0.15	12.15	12.6	2.3	1.2
MC-11	11	0.433	10.0		0.10	0.7		0.50	9.65		0.6		0.17	13.20	13.8	2.6	1.3
MC-12	12	0.472	10.9	-0.10	0.10	0.7		0.55	10.55	±0.18	0.6		0.20	14.35	15.0	2.8	1.6
MC-13	13	0.512	11.8		0.10	1.1		+0.15	0.60		11.40		1.0	±0.06	0.39	15.40	16.1
MC-14	14	0.551	12.7	-0.10	0.10	1.1		0.65	12.30	±0.18	1.0		0.42	16.30	17.0	5.5	2.1
MC-15	15	0.591	13.6		0.10	1.1		0.70	13.20		1.0		0.50	17.40	18.1	6.0	2.5
MC-16	16	0.630	14.5	-0.10	0.10	1.1		0.75	14.10	±0.18	1.0		0.51	18.50	19.2	6.3	2.9
MC-17	17	0.669	15.4		0.10	1.1		0.80	14.90		1.0		0.55	19.40	20.2	6.7	3.3
MC-18	18	0.708	16.3	-0.10	0.10	1.3		0.85	15.80	±0.18	1.2		0.67	20.40	21.3	8.5	3.6
MC-19	19	0.748	17.2		0.15	1.3		0.90	16.70		1.2		0.85	21.50	22.4	9.0	4.2
MC-20	20	0.787	18.1	-0.10	0.15	1.3		0.95	17.55	±0.18	1.2		0.85	22.65	23.6	9.5	4.6
MC-22	22	0.866	19.9		0.15	1.3		1.05	19.40		1.2		1.07	25.00	25.9	10.4	5.6
MC-23	23	0.905	20.8	-0.10	0.15	1.3		1.10	20.20	±0.18	1.2		1.15	26.00	27.0	10.9	6.1
MC-24	24	0.945	21.7		0.15	1.3		1.15	21.10		1.2		1.2	27.10	28.1	11.3	6.7
MC-25	25	0.984	22.6	-0.10	0.15	1.3		1.20	22.00	±0.21	1.2		1.4	28.30	29.3	11.8	7.4
MC-26	26	1.023	23.5		0.15	1.3		1.25	22.90		1.2		1.5	29.40	30.4	12.2	7.8
MC-28	28	1.062	25.2	-0.10	0.15	1.75		1.40	24.60	±0.18	1.6		2.5	31.60	32.6	17.6	9.5
MC-30	30	1.181	27.0		0.15	1.75		1.50	26.30		1.6		2.6	33.70	34.9	19.2	10.8
MC-32	32	1.260	28.8	-0.10	0.15	1.75		1.60	28.10	±0.18	1.6		3.2	36.10	37.3	20.5	12.2
MC-35	35	1.378	31.5		0.15	1.75		1.75	30.80		1.6		3.5	39.40	40.6	22.4	14.7
MC-36	36	1.417	32.4	-0.10	0.20	1.75		1.80	31.70	±0.25	1.6		4.1	40.50	41.7	23.1	15.7
MC-38	38	1.496	34.2		0.20	1.75		1.90	33.40		1.6		4.3	42.60	43.9	23.8	17.2
MC-40	40	1.575	36.0	-0.10	0.20	1.75		2.00	35.20	±0.18	1.6		4.7	45.00	46.3	25.6	19.6
MC-42	42	1.654	37.8		0.20	1.75		2.10	37.00		1.6		5.0	47.20	48.5	27.5	21.0
MC-45	45	1.772	40.5	-0.10	0.20	1.75		2.25	39.60	±0.18	1.6		5.4	50.60	52.1	28.4	24.5
MC-48	48	1.890	43.2		0.20	1.75		2.40	42.30		1.6		7.1	54.10	55.6	29.9	27.5
MC-50	50	1.969	45.0	-0.10	0.20	2.15		2.50	44.00	±0.39	2.0		8.9	56.40	58.0	40.0	30.4
MC-52	52	2.047	47.0		0.20	2.15		2.50	46.00		2.0		9.3	58.60	60.3	41.0	31.3
MC-55	55	2.165	50.0	-0.10	0.20	2.15		2.50	48.50		2.0		10.4	61.50	63.7	43.0	33.3

*F.I.M.(FULL INDICATOR MOVEMENT)-MAXIMUM ALLOWABLE DEVIATION OF CONCENTRICITY BETWEEN GROOVE AND SHAFT.

i BASED ON HOUSINGS/SHAFTS MADE OF COLD ROLLED STEEL. FOR AN EXPLANATION OF FORMULAS USED TO DERIVE THRUST LOAD AND OTHER PERFORMANCE DATA, CONTACT THE ROTOR CLIP ENGINEERING DEPT.

*** FOR PLATED RINGS ADD 0.05 TO THE LISTED MAXIMUM THICKNESS. MAXIMUM RING THICKNESS WILL BE A MINIMUM OF 0.005 LESS THAN THE LISTED GROOVE WIDTH (W) MINIMUM.

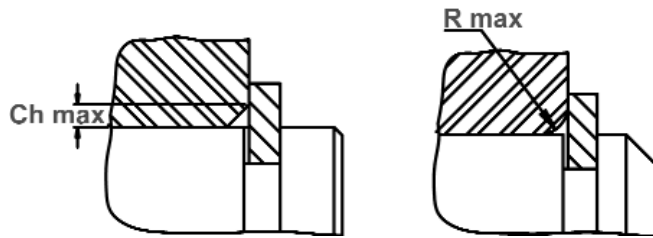

Maximum Corner Radius & Chamfer

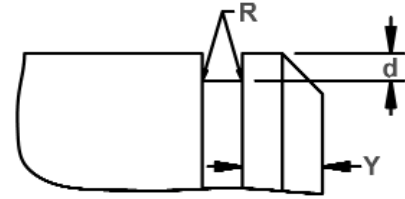

Exploded Groove Profile & Edge Margin (Y)
 Maximum bottom radii (R), 0.10 for ring sizes
 -3 thru -4; 0.20 for ring sizes -5 thru -16;
 0.30 for ring sizes -17 thru -30
 0.40 for ring sizes -32 thru -55

RING NO.	MAXIMUM SECTION	ALLOWABLE CORNER RADII & CHAMFERS		MAX. LOAD w/ R max or Ch max (kN)	EDGE MARGIN	R.P.M.
		Smax/Ref.	R max			
MC-3	0.90	0.4	0.30	0.4	1.0	80000
MC-4	1.00	0.4	0.30	0.4	1.2	80000
MC-5	1.20	0.6	0.45	0.7	1.5	80000
MC-6	1.30	0.6	0.45	0.7	1.5	80000
MC-7	1.40	0.6	0.45	0.7	1.5	69000
MC-8	1.60	0.6	0.45	0.7	1.5	67000
MC-9	1.70	0.6	0.45	0.7	1.5	58000
MC-10	1.70	0.6	0.45	0.7	1.5	50000
MC-11	1.80	0.6	0.45	0.7	1.5	40000
MC-12	1.90	0.6	0.45	0.7	1.7	35000
MC-13	2.00	1.0	0.8	2.0	1.8	30000
MC-14	2.00	1.0	0.8	2.0	2.0	27000
MC-15	2.10	1.0	0.8	2.0	2.1	25000
MC-16	2.20	1.0	0.8	2.0	2.3	24000
MC-17	2.25	1.0	0.8	2.0	2.4	23000
MC-18	2.30	1.2	0.9	2.8	2.6	21000
MC-19	2.40	1.2	0.9	2.8	2.7	20500
MC-20	2.55	1.2	0.9	3.0	2.9	20000
MC-22	2.80	1.2	0.9	3.0	3.2	16500
MC-23	2.90	1.2	0.9	3.2	3.3	15200
MC-24	3.00	1.2	0.9	3.2	3.5	15100
MC-25	3.15	1.2	0.9	3.2	3.6	15000
MC-26	3.25	1.2	0.9	3.2	3.8	14500
MC-28	3.50	1.5	1.15	6.3	4.2	13200
MC-30	3.70	1.5	1.15	6.4	4.5	13000
MC-32	4.00	1.5	1.15	6.6	4.8	12900
MC-35	4.30	1.5	1.15	6.8	5.3	11000
MC-36	4.40	1.5	1.15	6.8	5.4	10200
MC-38	4.60	1.5	1.15	7.1	5.7	9600
MC-40	4.90	1.5	1.15	7.2	6.0	9200
MC-42	5.10	1.5	1.15	7.4	6.3	8600
MC-45	5.50	1.5	1.15	7.6	6.8	8300
MC-48	5.90	1.5	1.15	7.9	7.2	7500
MC-50	6.20	2.0	1.5	12.0	7.5	6800
MC-52	6.30	2.0	1.5	12.0	7.5	6600
MC-55	6.50	2.0	1.5	12.0	7.5	6500

LARGER SIZES MAY BE AVAILABLE UPON REQUEST.

HARDNESS RANGES: STAINLESS STEEL RINGS (PH 15-7M0)

RING TYPE	SIZE RANGE	SCALE	ROCKWELL HARDNESS
MC	3-4	15N	82.5-86
	5-19	30N	63-69.5
	20-55	C	44-51

HARDNESS RANGES: CARBON STEEL RINGS (SAE 1060-1090)

RING TYPE	SIZE RANGE	SCALE	ROCKWELL HARDNESS
MC	3-4	15N	84-86
	5-19	30N	66-69.5
	20-55	C	47-51

